

PARTS LIST

- | | |
|---|--|
| 1 - LADDER (2007-10) | 2 - 3/8 H.D. FLATWASHERS (1 3/8" DIA.) |
| 1 - TOP SUPPORT BRACKET (2007 - 10) | 2 - 3/8 USS FLATWASHERS (1" DIA.) |
| 1 - LOWER SUPPORT BRACKET (2007 - 10) | 4 - 3/8 NYLON LOCK NUTS |
| 2 - 2" X 2" X 1/4" SPACERS | 1 - 5/16 X 1 1/4 CARRIAGE BOLT |
| 2 - 3/8 X 2 1/2 CARRIAGE BOLTS | 2 - 5/16 X 1 CARRIAGE BOLTS |
| 2 - 3/8 X 1 1/4 CARRIAGE BOLTS | 3 - 5/16 FLATWASHERS (11/16" DIA.) |
| | 3 - 5/16 NYLON LOCK NUTS |
| | 2 - 1/4 FLATWASHERS |
| | 1 - RUBBER BUMP STOP MOUNTING BRACKET |
| | 1 - RUBBER BUMP STOP KIT |
| | CARR-LANE # CL-14112-FC |

KIT CONTAINS
1 - 1/4 BUMP STOP
2 - 1/4 NUTS

INSTALLATION INSTRUCTIONS

- 1 - REMOVE THE TOP ROOF RACK MOUNTING BOLTS FROM THE DRIVERS SIDE REAR SUPPORT.
- 2 - INSTALL THE LADDER TOP SUPPORT BRACKET AS SHOWN (FIGURE A). SLIGHTLY TIGHTEN TO HOLD IN PLACE, FOR ADJUSTMENT LATER.

FIGURE A

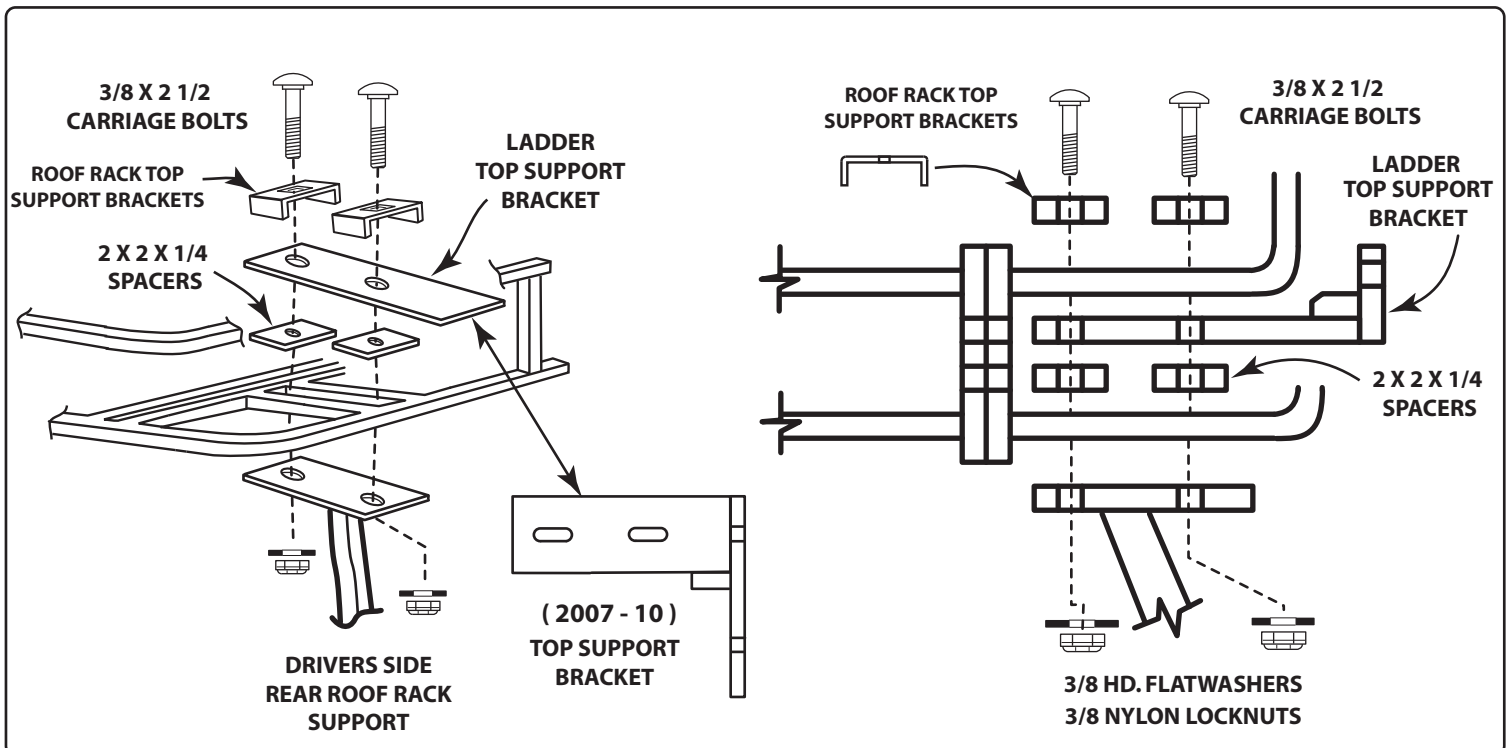

3 - MARK AND DRILL 5/16" DIA HOLE IN BRACKET AS SHOWN (FIGURE B). (EARLY PRODUCTION RACKS REQUIRE DRILLING, LATER PRODUCTION RACKS ALREADY HAVE A HOLE IN FROM THE FACTORY.

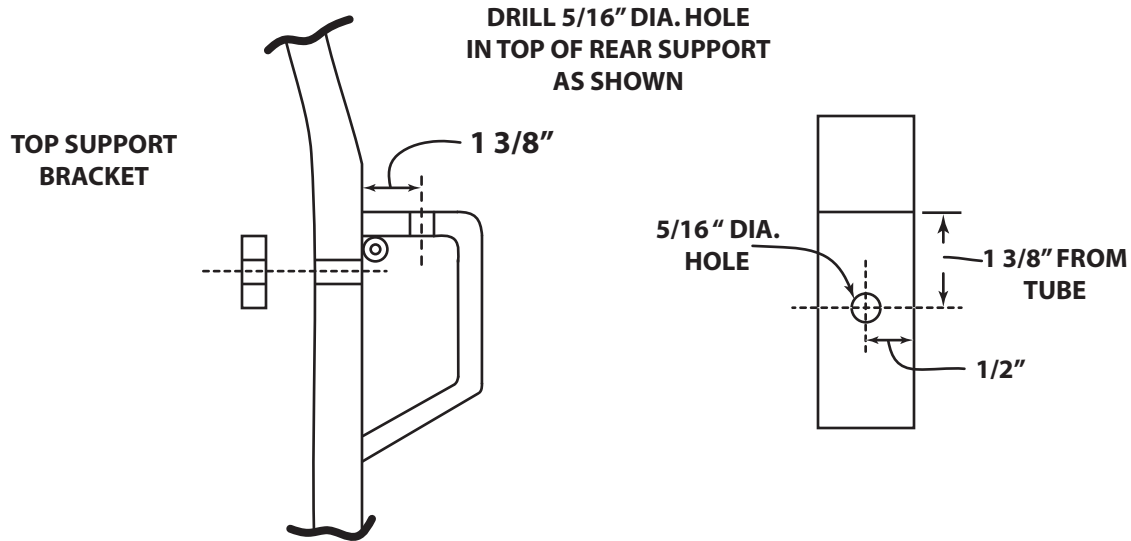

4 - INSTALL LOWER SUPPORT BRACKET AS SHOWN, SLIGHTLEY TIGHTEN TO HOLD IN PLACE.

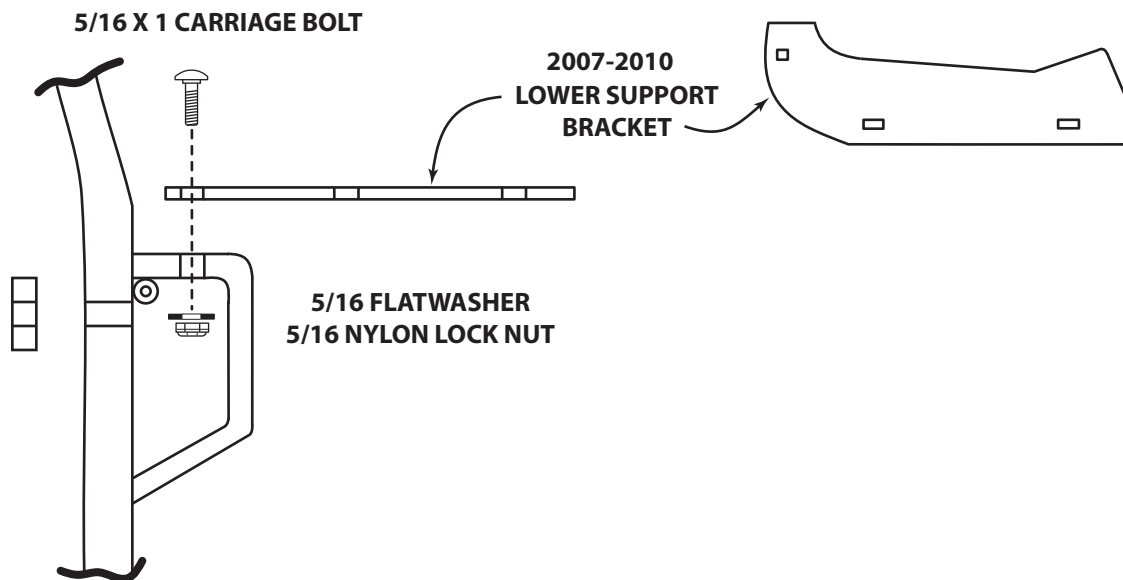

**5 - INSTALL LADDER TO TOP SUPPORT BRACKET AND BOTTOM SUPPORT BRACKET
LEAVE LOOSE FOR ADJUSTMENT.**

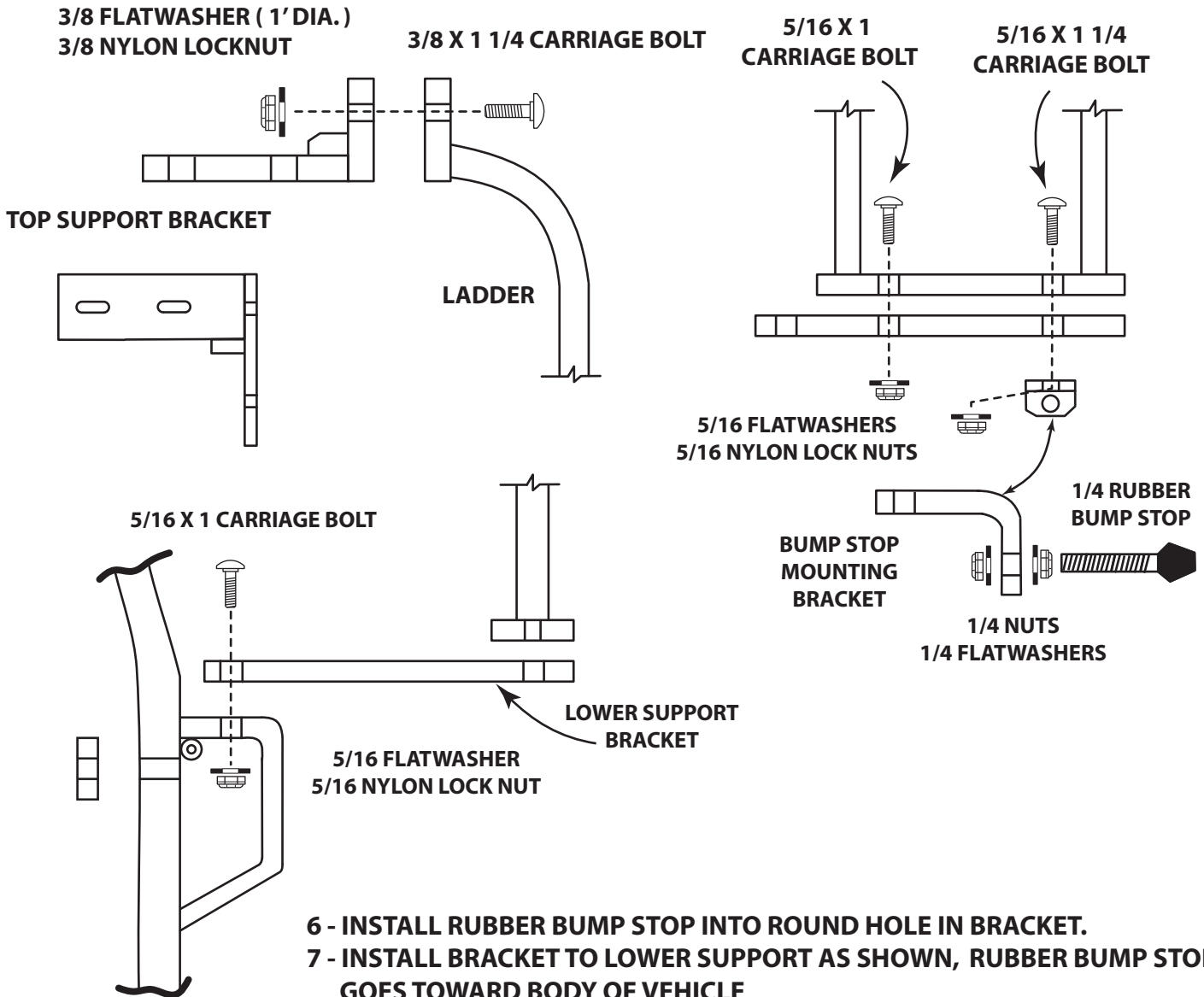

- 6 - INSTALL RUBBER BUMP STOP INTO ROUND HOLE IN BRACKET.
- 7 - INSTALL BRACKET TO LOWER SUPPORT AS SHOWN, RUBBER BUMP STOP GOES TOWARD BODY OF VEHICLE
- 8 - ALIGN AND TIGHTEN MOUNTING HARDWARE EASILY SO THE LADDER AND MOUNTING BRACKETS WILL CONFORM EVENLY.
- 9 - AFTER ALIGNING AND TIGHTENING ALL MOUNTING HARDWARE. ADJUST RUBBER BUMP STOP SO IT TOUCHES THE REAR BODY PANEL AND THEN TIGHTEN THE LOCKING NUTS.
- 10 - USE CAUTION WHEN CLIMBING ON THE LADDER.